

THERMAL, CONDENSATION AND FIRE PROTECTION

Data Centres

Data centres are the beating heart of the digital age. They power and protect mission-critical infrastructure. Maintaining defined ambient conditions is crucial to safeguarding their uptime and system reliability. Armacell's best-in-class insulation systems help to ensure long-term reliable operation, save energy and tackle climate change. **Freeze energy costs to build a sustainable digital future.**

www.armacell.com



Proven
solutions
for your
business



 **armacell**[®]
MAKING A DIFFERENCE AROUND THE WORLD

ABOUT ARMACELL

SOLUTIONS ENABLING ENERGY SAVINGS.

We are the inventors of flexible foams for equipment insulation and a leading provider of engineered foams. Our lightweight thermal, acoustic and mechanical solutions create sustainable value for our customers. Innovation and entrepreneurship are an integral part of our DNA. We drive industry-leading solutions and aspire to launch new technologies using alternative resources or natural feedstock.

Day in day out, our products significantly contribute to global energy efficiency and make a difference around the world. In meeting the challenges of megatrends, such as energy efficiency, noise control, lightweighting, the globalisation of food supplies, our product solutions stand out in terms of functionality and ease of installation.



3,000

employees worldwide
representing 70 different
nationalities

23

production facilities
in 15 countries on
4 continents

300+

active patents in
50 patent families

We create genuine value for our customers, value them as partners and are committed to developing solutions tailored to their requirements. The outcome is added value for our business partners and, most significantly, energy savings and a longer working life for their critical equipment.

Armacell. Making a difference around the world.

PROTECT YOUR ASSETS

KEEPING YOUR SYSTEMS COOL.



ENERGY
EFFICIENCY



CONDENSATION
CONTROL



INDOOR
AIR QUALITY



FIRE
SAFETY



LONG-TERM
SAFE OPERATION



The way we do business has shifted significantly and the COVID-19 pandemic has further accelerated digital transformation. Data has become the world's most valuable resource, the oil of the digital era, and data centres are the beating heart of the modern world. They have evolved from on-premise infrastructure to virtual networks that support applications and workloads in a multi-cloud environment. With economic resilience so closely linked to digital infrastructure and data demand growing exponentially, investment in innovative data centre technologies is essential.

Taken together, data centres already consume about three percent of the world's electricity. With more energy-intensive hyperscale facilities on the way, power demand is likely to increase. Servers housed in data centres generate vast amounts of heat and as much as 40 percent of total operational costs can be attributed to the energy required for cooling systems.

Long-term reliable solutions

Insulating cooling and HVAC equipment is one of the simplest and most efficient measures to save energy in data centres. Armacell's insulation solutions enhance the energy efficiency and tackle climate change by preventing CO₂ emissions. They increase fire safety, reduce sound emissions, minimise the risk of downtime due to unplanned maintenance work and can extend the service life of the insulated equipment.

02

INTRODUCTION

- 02 About Armacell
- 03 Keeping your systems cool

04

OUR SOLUTIONS

- 04 Energy efficiency
- 06 Protection against condensation
- 08 Indoor air quality
- 10 Fire safety
- 14 Long-term reliability

18

CUSTOMER EXPERIENCE

- 18 Beyond Better
- 19 Track record

HIGHER ENERGY EFFICIENCY. REDUCED CO₂ AND COSTS.

As much as 40 percent of a data centre's total operational costs are down to the energy needed to cool the massive amount of electronic equipment. Computer servers generate vast volumes of heat, so keeping the system cool is essential.



Tom Paris
Data centre planner
at Climaplan GmbH,
Munich (Germany)

“Data centres need a lot of energy to cool the servers. Insulating the cooling systems with AF/ArmaFlex increases the energy efficiency of the HVAC equipment and reduces CO₂ emissions.”

Data centre at the Technical University of Darmstadt (Germany)

When inaugurated in 2020, the Lichtenberg High Performance Computing cluster at the TU Darmstadt was the fastest supercomputer at a German university – listed on the table of the top 500 fastest supercomputers worldwide. Thanks to innovative HVAC equipment it is possible to work largely with free cooling all year round and to use the waste heat from the computer in the district heating network to heat buildings on the university campus. Armacell insulation materials were installed both on the cooling system for the Lichtenberg I computer and in the expansion of the project (Lichtenberg II) to protect the systems against energy losses and condensation.

AF/ArmaFlex®



There are two traditional technologies used to cool data centres: air-based and liquid-based cooling. Liquid cooling systems are increasing in popularity as they are more efficient at heat removal than the legacy floor-based cooling method which relies on delivering cooled conditioned air. Independent of the technology, all cooling designs need to be insulated properly to ensure reliable, long-term protection.



**ENERGY
EFFICIENCY**



**LOW TOTAL
INSTALLED COSTS**

OUR ENERGY-SAVING SOLUTIONS



Our insulation solutions enable considerable energy savings at comparatively low costs. Investments are generally recouped in less than a year and operators of data centres benefit from substantial energy- and cost-savings in the long term. ArmaFlex is our product heritage. The highly flexible, lightweight insulation features a closed-cell structure and combines a low thermal conductivity with an in-built water vapour barrier – protecting your assets from thermal losses and humidity.

ArmaFlex

saves 140 times more energy than is required for its production, according to an independent life-cycle analysis. No other energy-saving measure pays off as fast.

UP TO
75%

ENERGY SAVINGS
WITH ARMAFLEX
INSULATION*

COOLING
ACCOUNTS FOR UP TO

40%

OF DATA CENTRES'
TOTAL OPERATIONAL
COSTS

* In standard applications with an insulation thickness of 19 mm



PROTECTION AGAINST CONDENSATION AND CORROSION.

Information technology equipment is extremely sensitive to moisture. High humidity levels decrease the life expectancy of the equipment and moisture can lead to damage, corrosion and eventually equipment failure.



Roy van der Hoek
Director of
Van der Hoek Isolatatie

“We’ve been installing Armacell products very successfully for decades to protect technical installations against condensation, corrosion and energy losses. We have been certified by Armacell and work according to the ArmaFlex System Warranty. Product quality and workmanship you can rely on.”

Amsterdam 1 Data Center (The Netherlands)

Located in the Schiphol-Rijk district, the Amsterdam 1 Data Center (AMS1) will provide up to 40 MW of IT load across a space of 16,000 m² when completed. It is operated by Global Data Centers, a division of NTT Ltd., one of the world’s leading global technology services companies. The award-winning AMS1 is designed based on highly efficient and redundant adiabatic cooling systems that meet the highest energy efficiency standards. To prevent condensation and minimise the risk of corrosion, the complex cooling equipment was insulated with AF/ArmaFlex by V.D. Hoek Isolatatie (Amsterdam).

AF/ArmaFlex



To remain operational, data centres must be cooled. Even slight deviations from the defined climate conditions can cause tremendous damage. If the air is too dry, it can cause electrostatic discharge; if it is too humid, condensation can form.

Moisture on motherboards, in hard drives and in connecting sockets can lead to oxidation. If the humidity carries harmful pollutants which can trigger metal corrosion, it can result in data corruption, expensive repairs or even downtime.



CONDENSATION CONTROL



MITIGATES CORROSION UNDER INSULATION

OUR SYSTEM SOLUTIONS



If condensation forms on technical equipment, the consequences are far-reaching. Mould, corrosion, water dripping from suspended ceilings or downtime due to unscheduled maintenance work can soon result in high costs. We offer systems whose individual components are coordinated with each other and which are tested as a complete system. To ensure professional workmanship, trained ArmaFlex installers can be certified and receive an extended warranty on AF/ArmaFlex products.

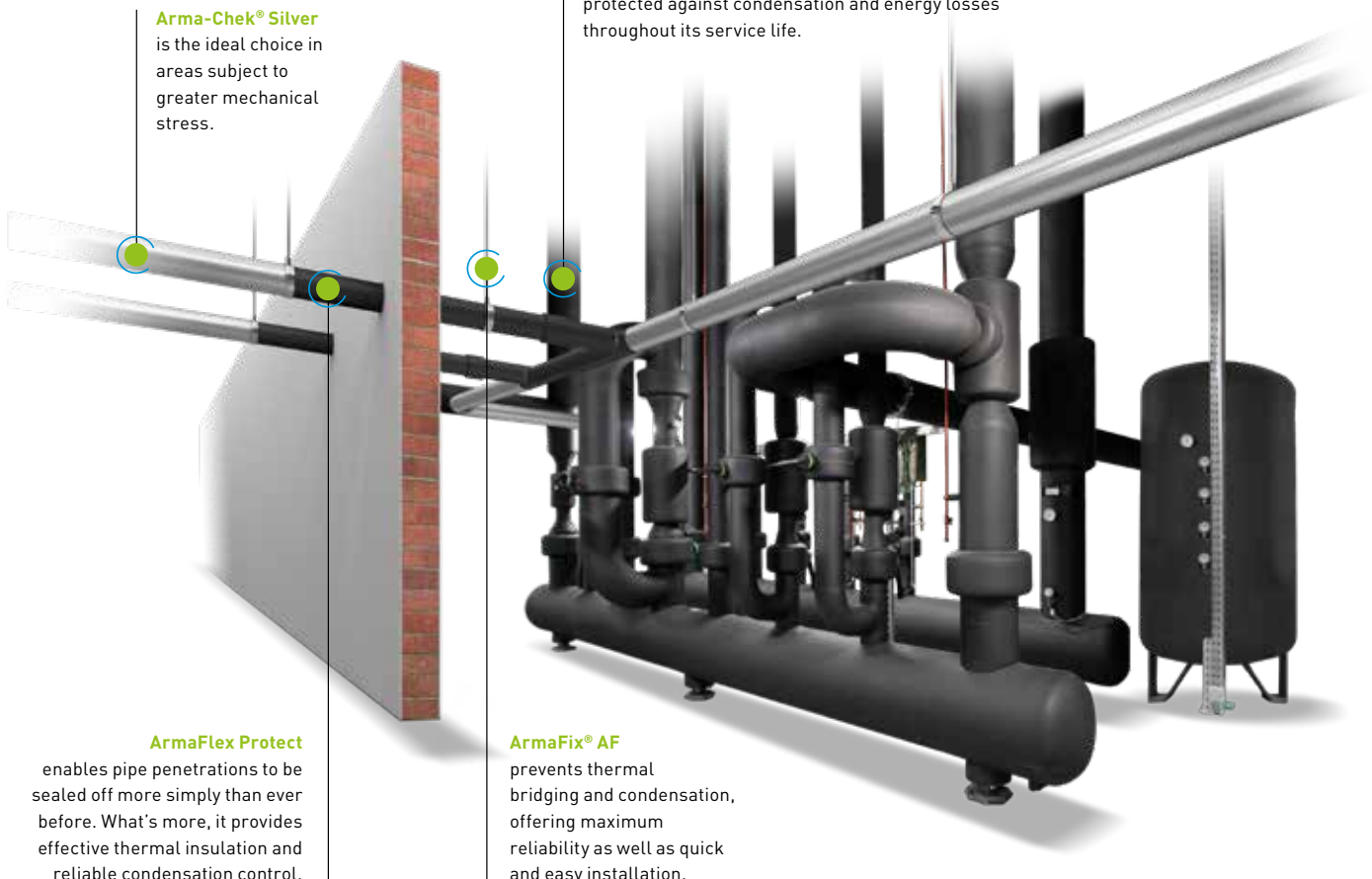

Arma-Chek® Silver is the ideal choice in areas subject to greater mechanical stress.

AF/ArmaFlex

offers superior performance at lower total installed cost. This material ensures that equipment is reliably protected against condensation and energy losses throughout its service life.

ArmaFlex Protect enables pipe penetrations to be sealed off more simply than ever before. What's more, it provides effective thermal insulation and reliable condensation control.

ArmaFix® AF prevents thermal bridging and condensation, offering maximum reliability as well as quick and easy installation.

INDOOR AIR QUALITY. PREVENTION OF AIRBORNE CONTAMINATION.

Contamination is a constant threat to sensitive equipment in data centres. Dust particles and corrosive gases can compromise the energy efficiency and damage IT equipment over time.



John-Ove Wallberg
Department Manager Insulation
Gävle/Borlänge at Bilfinger
Industrial Services Sweden

“AF/ArmaFlex prevents condensation and does not release dust, fibres or other particles that could interfere with the performance of sensitive IT equipment in the critical environment of a data centre.”

EcoDataCenter, Falun (Sweden)

The EcoDataCenter is the world's first climate-positive data centre. The site in Falun is powered entirely by renewable energy sources. The excess heat from this large-scale facility is led back to a heating plant where it is used to heat surrounding properties and in the production of renewable biofuel (pellets). Since the site is designed to be as energy efficient as possible, the innovative chassis-based liquid cooling system was insulated with AF/ArmaFlex.

AF/ArmaFlex



One of the biggest risks to the performance of data centres are invisible pollutants that are often spread by the ductwork of HVAC systems in the facility. Harmful contaminants such as particulate, gases and microbes can harm sensitive server, network and data storage equipment. Since HVAC units are critical components to the indoor air quality, only insulation that does not release dust or fibres must be used in these mission-critical 'clean room' environments.



DUST- AND FIBRE-FREE



PROTECTION AGAINST MICROORGANISMS

OUR SOLUTIONS FOR CLEANROOMS

Dust- and fibre-free, ArmaFlex products provide protection against contamination and micro-organisms. It is much more difficult for microbes to settle on the smooth, non-porous surface of the elastomeric material than in open-cell mineral fibre. Due to its closed-microcell structure and high resistance to water vapour transmission, ArmaFlex insulation has reliable protection against condensation and moisture ingress. Plus, it has extremely low VOC emissions and can contribute to green building certification schemes.

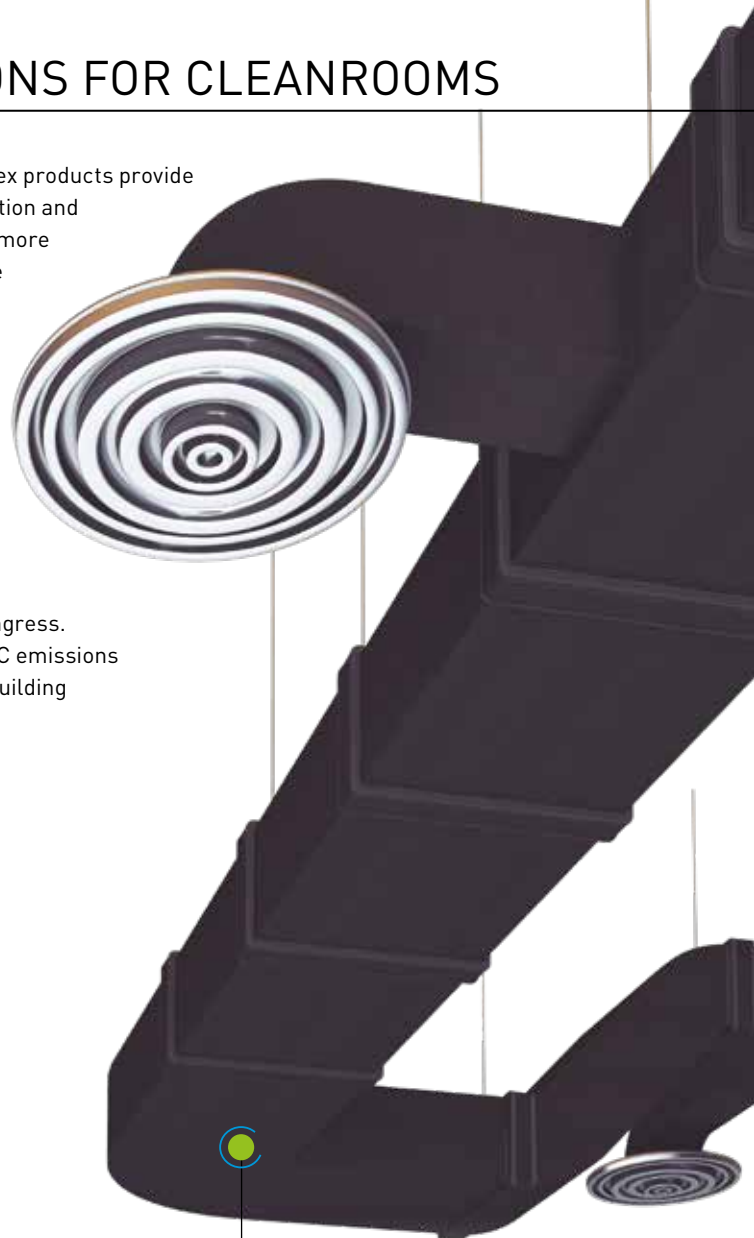

PROTECTION THAT LIVES ON
MICROBAN

Armacell is the only manufacturer of flexible technical insulation materials to provide its premium products with built-in antimicrobial protection: AF/ArmaFlex and SH/ArmaFlex are equipped with Microban®. These antimicrobial additives provide 'proactive' protection against harmful bacteria, mould and mildew.

AF/ArmaFlex

Our closed-cell, dust- and fibre-free insulation does not release harmful particles and is equipped with Microban technology, making it an excellent choice for data centres.

FIRE SAFETY IS A TOP PRIORITY.

Fires can never be completely ruled out and they occur unexpectedly. In the event of a fire, toxic gases which can form aggressive acids in combination with water often cause greater damage than the fire itself.



Jörg Uhlig
Owner of Uhlig-Isolierung
(Lübben, Germany)

“In a fire, corrosive gases in combination with fire-fighting water could form aggressive acids and cause considerable consequential fire damage. Halogen-free NH/ArmaFlex releases no corrosive gases.”

Comarch AG, Dresden (Germany)

In just 15 months, Comarch AG, a global software house, built a new Tier III standard data centre in Dresden. The complex consists of a new build and a Wilhelminian-era building, which was renovated to a high standard. It houses a data centre as well as offices and training rooms. Halogen-free NH/ArmaFlex was used to insulate the cooling pipes in the server rooms. The equipment in the cooling and ventilation plant room and the air ducts in the offices were insulated with AF/ArmaFlex. Parts of the insulated equipment were then clad with Okabell metal sheets.

NH/ArmaFlex

AF/ArmaFlex

Okabell®



Fires are a major cause of extended data centre failures. The high density of electrical power increases the potential fire hazard. Though fire might not be the highest potential risk, it can have far-reaching consequences. If not detected and extinguished immediately, data can be irretrievably destroyed, and repairing and restoring the facility will incur high costs. IT downtime and business interruption can also cost companies dearly.



LOW SMOKE DENSITY IN A FIRE



FIRE PROTECTION

OUR FIRE PROTECTION SOLUTIONS

Insulation materials used in data centres must be highly flame retardant and have low smoke emission.

// NH/ArmaFlex Smart

In a fire, our halogen-free NH/ArmaFlex Smart releases no corrosive gases, which could form aggressive acids in combination with fire-fighting water.

// ArmaFlex Ultima

is B₁-s1,d0 classified and develops 10 times less smoke than traditional elastomeric products in a fire.



// ArmaFlex Protect

Our fire protection barrier ArmaFlex Protect and our ArmaProtect™ System products have intumescent and ablative components which prevent fire spreading. The highly flexible ArmaFlex Protect also ensures effective thermal insulation and reliable condensation control.

NH/ARMAFLEX SMART. INNOVATION RELOADED.

NH/ArmaFlex Smart

With this innovative solution we are taking our halogen-free insulation materials to the next level. Based on an innovative foam technology, the new material combines tried-and-trusted fire properties and high environmental sustainability with greatly improved flexibility and excellent UV and ageing resistance.

NH/ArmaFlex Smart. No halogens. No compromises.



EXCELLENT FIRE BEHAVIOUR

NH/ArmaFlex Smart releases 50 percent less smoke than conventional flexible elastomeric foam products. In the event of a fire, smoke hinders visibility, making it difficult to locate escape and rescue routes. Consequently, experts attach greater importance to smoke development and smoke density than to heat release.

LESS CONSEQUENTIAL FIRE DAMAGE

In a fire, NH/ArmaFlex Smart does not release corrosive gases, which in combination with extinguishing water can form aggressive acids. In areas requiring special protection, such as data centres or clean room industries, consequential fire damage can soon amount to many times the cost of the actual fire damage.



When we launched NH/ArmaFlex in 1996, we were the first manufacturer to offer halogen-free elastomeric equipment insulation. An innovation that soon established itself as an environment-friendly standard in technical insulation.

RESISTANT TO UV-LIGHT AND AGEING

NH/ArmaFlex Smart has excellent UV- and ageing resistance. The resistance to light ageing was confirmed in accelerated radiation tests. The halogen-free insulation material has outstanding light stability. Indoors it can be exposed to natural and artificial light without the need for additional cladding.

PREVENTS STRESS CORROSION CRACKING

Stress corrosion cracking can occur on austenitic stainless steels when stresses, moisture and chlorine ions occur simultaneously. As a halogen-free product, NH/ArmaFlex Smart can minimise the risk of stress corrosion cracking.

HIGH ENVIRONMENTAL SUSTAINABILITY

NH/ArmaFlex Smart is halogen-free; it contains neither PVC nor chlorinated polyethylene. It is produced without adding brominated flame retardants and is free of chlorinated paraffins. Short-chain chlorinated paraffins are considered hazardous to health and the environment and their production has been discontinued in Europe. NH/ArmaFlex Smart contains neither short-, medium- nor long-chain chlorinated paraffins. The product meets the German Sustainable Building Council's highest quality level for flame-retardant building products.

EXTREMELY LOW SMOKE DENSITY

ArmaFlex Ultima

THE FIRST FLEXIBLE INSULATION WITH
B_L-s1,d0 FOR INCREASED PEOPLE SAFETY

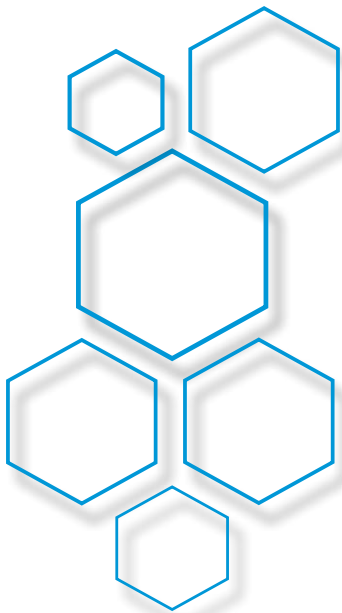

With ArmaFlex Ultima we have set a new safety standard in technical insulation. Based on the patented ArmaPrene® technology, ArmaFlex Ultima is the first flexible technical insulation material in the world with fire class B_L-s1,d0.

In comparison to a standard elastomeric product, the flame-resistant insulation material exhibits 10 times less smoke and offers increased safety in the event of a fire.

Up to
10
times less
smoke



ULTRA-LOW SMOKE PROPERTIES

As smoke is a significant risk in a building fire, smoke density requirements for equipment insulation materials are becoming stricter. When assessing the fire behaviour of building products, the European fire classification not only tests the flammability, but also the smoke density and the production of burning droplets. By reducing the smoke density, ArmaFlex Ultima improves visibility and respiration, thus extending the time available to evacuate safer in the event of a fire.



RELIABLE THERMAL AND CONDENSATION CONTROL

Thanks to its low thermal conductivity and high resistance to water vapour diffusion, the closed-cell ArmaFlex Ultima ensures reliable condensation control and high energy savings in the long-term. This also minimises the risk of corrosion under insulation and reduces the risk of costs associated with downtime, lost productivity, or even facility shutdown.

SYSTEM SOLUTION FOR MAXIMUM RELIABILITY

The ArmaFix Ultima pipe support thermally isolates the pipe and its fixing from each other and, together with the adjoining ArmaFlex Ultima insulation, forms a long-term reliable insulation system. For the installation of ArmaFlex Ultima, we offer a range of specially formulated adhesives, including a solvent-free product which is predestined for sustainable construction projects realised according to LEED, BREEAM, DGNB or national building schemes.

ENVIRONMENTAL AND HEALTH SAFETY

ArmaFlex Ultima offers a high level of safety in ecological and health terms. The product achieves the highest fire classifications without the use of brominated flame retardants and the material is free of PVC. ArmaFlex Ultima fulfils the strict requirements of the Nordic Swan Ecolabel, Swedish SundaHus and is listed by Byggarubedömningen (BVB) and the Swiss Minergie-Eco label.

LONG-TERM RELIABILITY. SAFEGUARDING OPERATION.

As a society, we depend heavily on the reliability of our digital services. To keep the digital economy running and to protect valuable data and virtual assets, an uncompromising level of performance has to be achieved. Downtime is not an option.



Martin van den Bos
Director at Gelders Isolatiebedrijf
in Apeldoorn (The Netherlands)

“The reliability and durability of the product is crucial when selecting a technical insulation material for cooling equipment. We have been using AF/ArmaFlex very successfully for over 40 years. No other insulation material can be installed as simply, cleanly and reliably on cooling equipment.”

Data Centre, Apeldoorn (The Netherlands)

ArmaFlex has been the material of choice in many data centres for decades. In 2020, the insulation contractor GIB (Gelders Isolatiebedrijf) was asked to insulate the new cooling equipment of an HVAC system for an extension of a large data centre in Apeldoorn. To prevent condensation and ensure energy savings which can be relied on in the long term, cooling equipment was insulated with AF/ArmaFlex. Parts of the existing cooling systems date back to the early 1980s and were insulated with AF/ArmaFlex at that time. Unbelievable, but true: the insulation is still in use and fully functional.

AF/ArmaFlex (1983 – 2020)



The reliability of data centres is more essential than ever. Their 24/7 operation is critical to the functioning of our world with IT outages affecting both businesses and consumers. Data centres are unlike any other buildings and must be protected as best as possible to ensure operational performance. Installing the latest technology can go a long way towards improving long-term reliability and effectiveness.



In service for 40 years and still preventing condensation and energy losses as reliably as on the day it was installed. What more can you ask for from a technical insulation material?



We wanted to know if the impeccable visual appearance of this **40-year-old AF/ArmaFlex insulation** is matched by its technical performance. The insulation contractor was allowed to take a sample and replace it with new material. The insulated pipe was dry and showed no corrosion under the insulation.



The sample was sent to Armacell's testing department and underwent extensive research. **After almost 40 years in operation this old piece of AF/ArmaFlex still has the technical properties we guaranteed when it was sold.** The thermal conductivity was even better than promised.

INSTALL IT. TRUST IT.



40
YEARS IN
OPERATION

DESIGNED FOR LONGEVITY

Did you know that 98 percent of all insulation failures are moisture related? Inadequate insulation can result in condensation, reduced thermal performance, mould growth and cost-intense consequential damage. As confirmed by the renowned Fraunhofer Institute for Building Physics in Stuttgart (Germany), ArmaFlex is very well protected against moisture ingress. The closed-cell material has an integrated vapour barrier and the water vapour resistance is built up cell by cell throughout the insulation material. This is the key to the longevity of our products. The highest possible reliability of the technical insulation is essential for long-term operation of the cooling systems in data centres.

Go BEYOND BETTER to prevent moisture ingress, thermal losses, corrosion under insulation and system failure.

1954

The first flexible technical insulation material – **ArmaFlex** – is presented by our former parent company Armstrong in the USA.

1978

Benchmark-setting **AF/ArmaFlex** with engineered wall thicknesses is launched in Europe.

1993

The patented **ArmaFix AF pipe support** ensures a reliable insulation system in the sensitive area of the pipe bracket.

2006

By developing a much finer cell structure the technical properties of AF/ArmaFlex are further improved: $\mu \geq 10,000$ and $\lambda_{0°C} \leq 0.033 \text{ W/(m} \cdot \text{K)}$.

AF/ArmaFlex Evo

WELCOME TO THE NEXT LEVEL IN THE EVOLUTION OF AF/ARMAFLEX TECHNOLOGY.

Since its launch in 1978, we have continuously improved our AF/ArmaFlex premium solution.

Over the last four decades we have enhanced the technical properties of this closed-cell foam by increasing the water vapour resistance and reducing the thermal conductivity. The better an insulation material is protected against moisture penetration, the more reliable and energy efficient it is.



AF/ArmaFlex Evo.
Install it. Trust it.

-  PREVENT CONDENSATION
-  SAVE ENERGY
-  ENSURE FIRE SAFETY

Today, in its 8th product generation, we present a new AF/ArmaFlex technology that combines excellent condensation control and energy efficiency with advanced fire safety. The new B/B_L-s2,d0 product provides highest insulation reliability and contributes to the overall safety in buildings.

2009



Introduction of the ArmaFlex System Warranty, a unique partner approach for trained and certified contractors.

2010



Built-in Microban® antimicrobial product protection inhibits the growth of mould and mildew in the insulation.

2020



Launch of AF/ArmaFlex Evo, the new AF/ArmaFlex for greater safety in the event of a fire.

AF/ArmaFlex.
Always the best product of its time.

ARMACELL GOES BEYOND BETTER.



At Armacell, we are committed to creating an exceptional customer experience. We understand the challenges when planning today's state-of-the-art data centres and are here to help you complete your projects successfully. From the planning stage to the handover – our 360° service supports you throughout.

ARMACELL APPLICATION TRAINING

To ensure that our thermal and acoustic insulation materials are installed properly, Armacell has trained thousands of installers around the world. Special training centres have been set up at many locations and we also provide valuable support on site. Several thousand insulators attend courses on installing Armacell products every year and are awarded the ArmaFlex application certificate.

EPDS FOR SUSTAINABLE BUILDING ASSESSMENT

Armacell is the first manufacturer of flexible technical insulation materials to present third-party verified environmental product declarations (EPDs). They are based on an independent lifecycle assessment (LCA) and are the key to designing green buildings in accordance with green-building schemes, such as LEED, BREEAM®, DGNB, HQM, and others.

ARMWIN – PROFESSIONAL INSULATION CALCULATIONS

With our powerful ArmWin software you can carry out all common technical calculations – even on the building site, thanks to the app. You can easily determine the minimum insulation thickness required for condensation control, plus surface temperature, heat flow, temperature changes in flowing and stationary media, freezing times for water pipes and the most economical insulation thicknesses, i.e. those with the shortest pay-back periods.



ArmWin
All technical insulation calculations in one tool.

BIM PLUG-IN FOR PLANNING TECHNICAL INSULATION



The future of construction is digital: Business Information Modelling (BIM) allows mechanical equipment to be planned, built and operated digitally from design to commissioning, maintenance, demolition and disposal. Armacell's BIM plug-in is seamlessly integrated in the Autodesk® Revit® programme and provides key product information. The software accesses the data required directly in the model and supports the user in choosing and configuring products.

DATA CENTRES AROUND THE WORLD RELY ON OUR PROVEN SOLUTIONS.



Just a few of the **successful projects**:

// **China**

China Securities and Futures Industry
South Information Technology Centre,
Guangdong
China Mobile, Guangdong

// **Germany**

Lichtenberg High Performance Computer
of Technical University, Darmstadt
Comarch AG, Dresden

// **India**

Amazon India Pvt. Ltd., Bangalore
BNP Paribas, Bangalore
NTT-NetMagic DC7, Mumbai

// **Kuwait**

Boubyan Bank Data Center, Kuwait City

// **The Netherlands**

Amsterdam 1 Data Center, Amsterdam
Dataplace Data Center

// **Spain**

Data centre of BBVA in Tres Cantos,
Madrid

// **Sweden**

EcoDataCenter, Falun

// **USA**

Google Data Center, Texas
Facebook Data Center, Utah
Microsoft Data Center, Illinois
CloudHQ Data Center (LC2), Virginia
Intel Ronler Acres Campus, Oregon

PERFORMANCE BEYOND BETTER

**SMART SOLUTIONS
FOR YOUR BUSINESS**

**Enjoy the benefits of our
excellent customer service.**

All over the world, our customers
rely on sales representatives,
technical consultants and
applications engineers.

Your project demands more. You
deserve the best solution. Get the
original closed-cell thermal and
acoustic solutions from Armacell.



**Armacell Goes
Beyond Better.
Driving performance
beyond the expected
– supporting you
today and tomorrow.**

All data and technical information are based on results achieved under the specific conditions defined according to the testing standards referenced. Despite taking every precaution to ensure that said data and technical information are up to date, Armacell does not make any representation or warranty, express or implied, as to the accuracy, content or completeness of said data and technical information. Armacell also does not assume any liability towards any person resulting from the use of said data or technical information. Armacell reserves the right to revoke, modify or amend this document at any moment. It is the customer's responsibility to verify if the product is suitable for the intended application. The responsibility for professional and correct installation and compliance with relevant building regulations lies with the customer. This document does not constitute nor is part of a legal offer to sell or to contract. At Armacell, your trust means everything to us, so we want to let you know your rights and make it easier for you to understand what information we collect and why we collect it. If you would like to find out about our processing of your data, please visit our [Data Protection Policy](#).

© Armacell, 2021. All rights reserved. Trademarks followed by ® or ™ are trademarks of the Armacell Group. Microban® is a trademark of Microban Products Company and is used herein with permission. LEED® stands for Leadership in Energy and Environmental Design™. LEED®, and its related logo, is a trademark owned by the U.S. Green Building Council® and is used herein with permission. UL, the UL logos and the UL mark are trade-marks of UL LLC© 2013. AutoDesk® and Revit® are registered trademarks of Autodesk, Inc.

00554 | Data Centres Solutions | MktBrochure | 112021 | EMEA | EN MASTER

ABOUT ARMACELL

As the inventors of flexible foam for equipment insulation and a leading provider of engineered foams, Armacell develops innovative and safe thermal, acoustic and mechanical solutions that create sustainable value for its customers. Armacell's products significantly contribute to global energy efficiency making a difference around the world every day. With 3,000 employees and 23 production plants in 15 countries, the company operates two main businesses, Advanced Insulation and Engineered Foams. Armacell focuses on insulation materials for technical equipment, high-performance foams for high-tech and lightweight applications and next generation aerogel blanket technology. For more information, please visit: www.armacell.com.

For product information, please visit:
www.armacell.eu

MAKING A DIFFERENCE AROUND THE WORLD